

TITLE: techlab	
Document Number:	REV:
Date: 1/21/19 5:11 PM	Sheet: 1/1

1

2

3

4

5

6

A

A

B

B

C

C

D

D

E

E

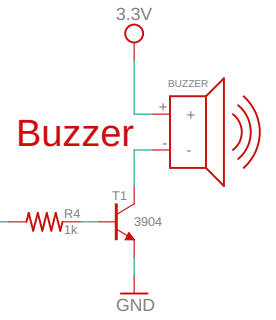
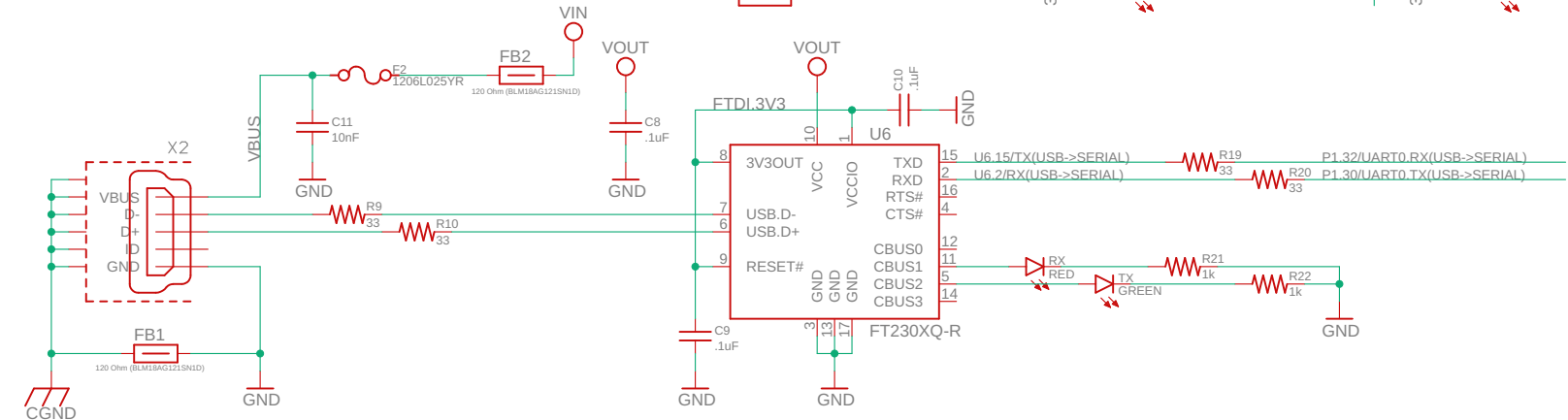
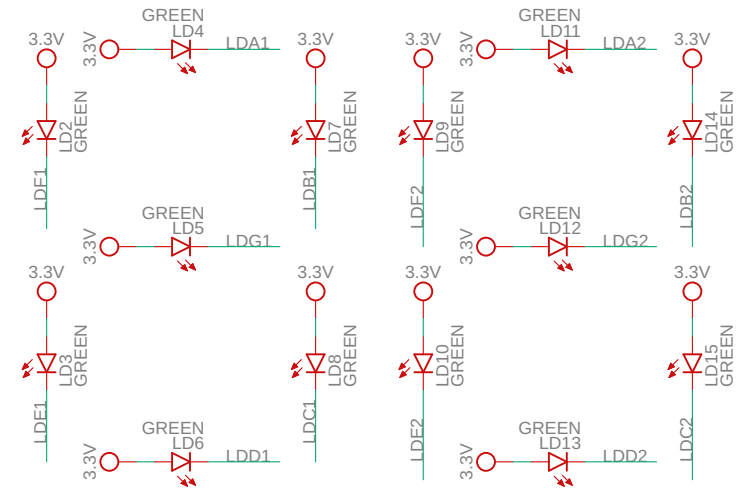
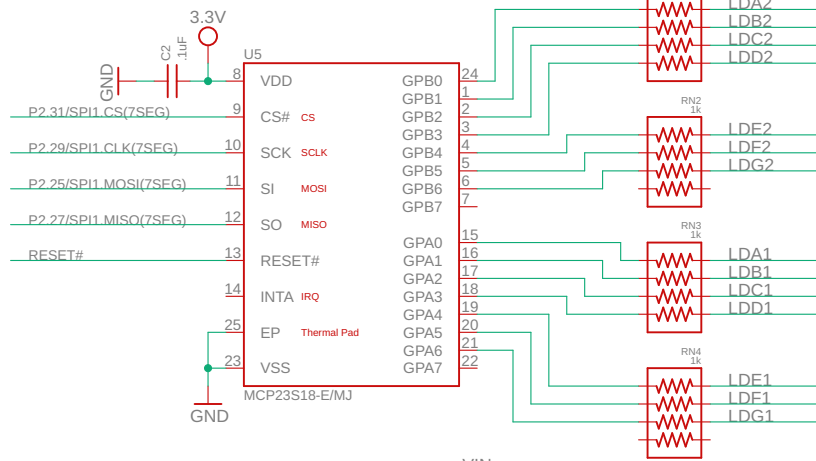

Multi-colored LED (Bulb)

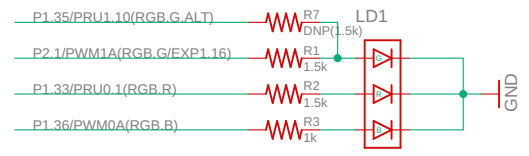

Light Sensor

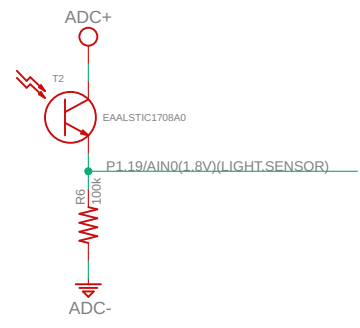

TITLE: techlab	
Document Number:	REV:
Date: 1/21/19 5:11 PM	Sheet: 1/1