

Coral

USB Accelerator Datasheet

Version 1.2

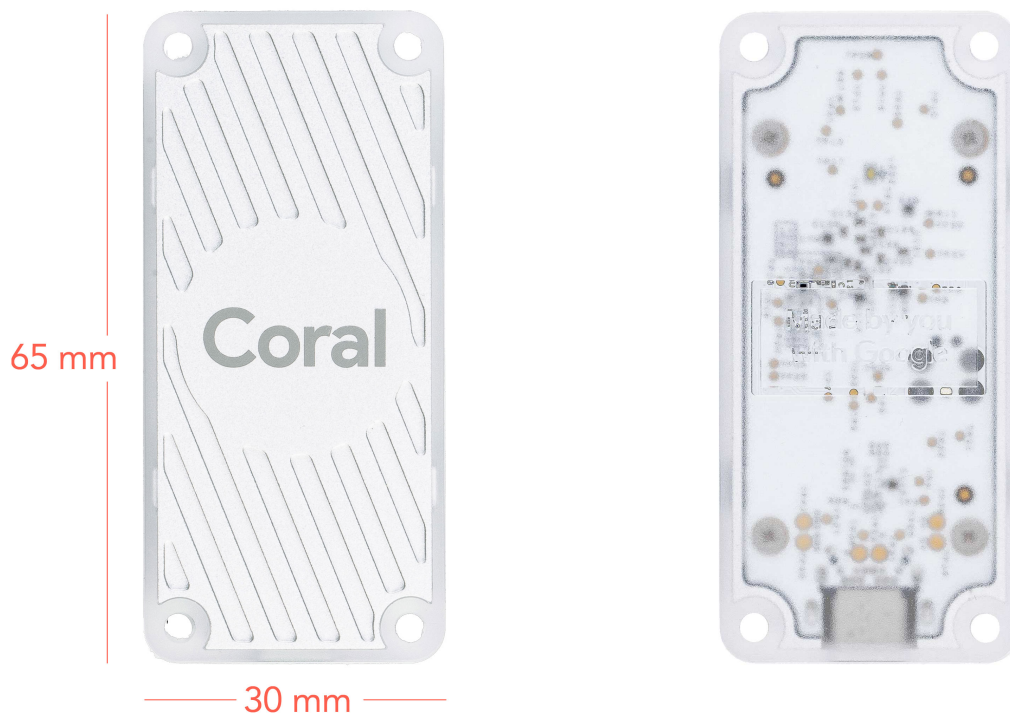

Features

- Google Edge TPU ML accelerator coprocessor
- USB 3.0 (USB 3.1 Gen 1) Type-C socket
- Supports Linux, Mac, and Windows on host CPU

Overview

The Coral USB Accelerator adds an Edge TPU coprocessor to your system. It includes a USB socket you can connect to a host computer to perform accelerated ML inferencing.

The on-board Edge TPU is a small ASIC designed by Google that provides high performance ML inferencing with a low power cost. For example, it can execute state-of-the-art mobile vision models such as MobileNet v2 at almost 400 FPS, in a power-efficient manner.

Table of contents

- System requirements
- Components overview
- Product dimensions
- Software and operation
 - Performance settings
 - LED behavior
- Power specifications
- Performance settings
- Recommended operating conditions
- Environmental and electrical reliability tests
- Mechanical reliability tests
- Certifications
- Document revisions

System requirements

- One of the following operating systems:
 - Linux Debian 6.0 or higher, or any derivative thereof (such as Ubuntu 10.0+), and an x86-64 or ARM64 system architecture
 - macOS 10.15, with either [MacPorts](#) or [Homebrew](#) installed
 - Windows 10
- One available USB port (for the best performance, use a USB 3.0 port)
- Python 3.5, 3.6, or 3.7

Component overview

The Coral USB Accelerator is a small PCB that provides an Edge TPU coprocessor for your host CPU system.

Table 1. Coral USB Accelerator components and features

Feature	Details
ML accelerator	
Edge TPU	<ul style="list-style-type: none">• ASIC designed by Google that provides high performance ML inferencing for TensorFlow Lite models
Connections	
USB	<ul style="list-style-type: none">• USB 3.0 (USB 3.1 Gen 1) port and cable (SuperSpeed, 5 Gbps)• Included cable is USB Type-C to Type-A, and 300 mm (12 in) in length

Product dimensions

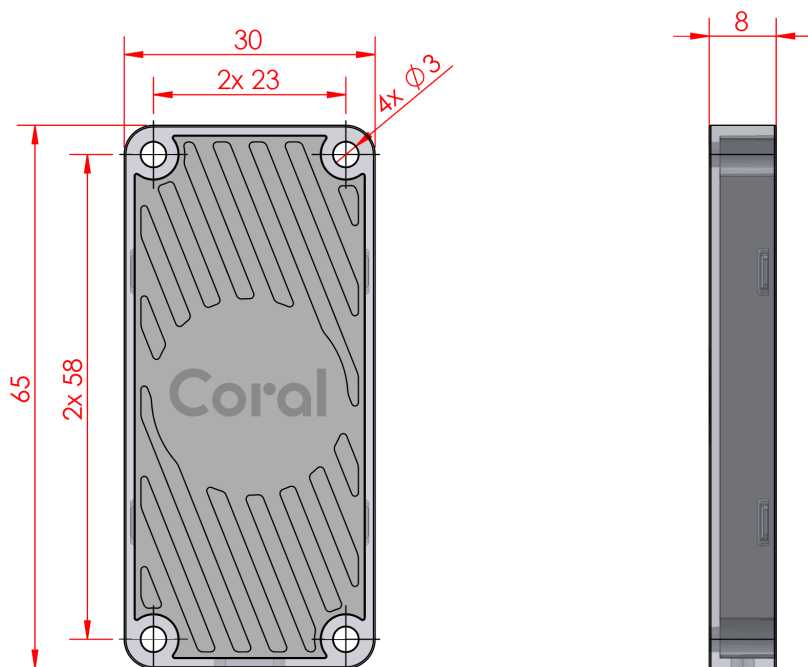

Figure 1. USB Accelerator dimensions and mounting hole details

USB cable length: 300 mm \pm 20 mm

Software and operation

The USB Accelerator does not require any software to be installed, but the host computer must have the Edge TPU runtime and API library. Instructions on how to install these are included in the guide for how to [get started with the USB Accelerator](#).

For information about how to create models and run inferences on the Edge TPU, read the documentation for [TensorFlow models on the Edge TPU](#).

Performance settings

When you [first set up the USB Accelerator](#), you can select whether the device operates at the default clock frequency or the maximum clock frequency. The maximum clock frequency is twice the default setting, which increases the inferring speed but also increases [power consumption](#).

Caution: If you set up the device to operate at the maximum clock frequency, the USB Accelerator can become very hot to the touch during operation. This might cause burn injuries. To avoid injury, either keep the device out of reach when operating it at maximum frequency, or use the default clock frequency.

To change the clock frequency at which the device operates, simply install the alternative runtime, as described in the instructions for how to [install the Edge TPU runtime](#).

LED behavior

The USB Accelerator includes an LED that indicates the current system state. The following table describes the behavior of the LED.

Table 2. USB Accelerator LED behavior and meaning

System state	LED behavior
Edge TPU initialized	On (solid)
Edge TPU running	Pulse (breathe)

Power specifications

The USB Accelerator is powered by 5 V from the USB interface through on-board power management chip (PMIC).

The device should be connected to a host computer with a USB cable that provides at least 500 mA at 5 V. Please note that when the device **runs at maximum speed**, it can draw a peak current of 900 mA.

Recommended operating conditions

Depending on the computation workloads and operating frequency, the USB Accelerator may heat up during normal operation. Contact with the metal part of the device may lead to discomfort and/or skin burns if the device has been operating for an extended period. We recommend the following operating temperature ranges, depending on the operating frequency you have selected.

Table 3. USB Accelerator operating conditions

Operating frequency	Maximum ambient temperature
Default	35° C
Maximum	25° C

Google does not accept any responsibility for loss or damage if the device is handled unsafely or operated outside of the recommended ambient temperature range.

Environmental and electrical reliability tests

Table 4. Verified results for USB Accelerator environmental and electrical reliability tests

Test	Conditions	Verified
Heat soak	Non-op: 60° C @ 90% RH	72 hrs
Temp cycling	Non-op: -20° C @ 60° C	300 cycles
Short term survivability	Non-op: 85° C @ 20% RH, 18 hrs	18 hours
Long-term operational stress (LTOS)	Op: 40° C @ 90% RH	1000 hours
ESD - Air discharge	15~35° C, 30~60% RH	12 kV
ESD - Contact discharge	15~35° C, 30~60% RH	8 kV

Mechanical reliability tests

Table 5. Verified results for USB Accelerator mechanical reliability tests

Test	Conditions	Verified
0.5 m controlled drop on wood	6 faces, 12 edges, 3/4" wood	18 drops
0.5 m tumble	Impact surface: steel plate > 3 mm thick	50 drops
Repetitive drop	75 mm drop on plywood, six faces	50 drops
Vibration	3 axes (X, Y and Z), 15 minutes per axis, 10-500 Hz. Amplitude: 2.16 Grms	45 minutes
USB-C connector cycling	Manual plug/ unplug	1000 cycles
USB-C connector side load 2.5 kg	2.5 kgf load, 15 mm from the plug, 2 orientations	50 cycles
Pressure & squeeze - 50 kg	50 kgf, 100 mm rubber pad	10 cycles
Pressure & squeeze - 5 kg	5 kgf, 10 mm rubber pad	10 cycles
USB cable 120° bend	60° CW + 60° CCW, 453 gf tension, 42 rpm	100 cycles

Certifications

Table 6. USB Accelerator certifications

Country	Agency
USA	FCC
European Union	CE
Hong Kong	CE
Japan	VCCI
Korea	KC

CAD files

Table 7. USB Accelerator 3D CAD file

File	Description
Coral-USB-Accelerator.STEP	3D CAD file in STEP format

Document revisions

Table 8. History of changes to this document

Version	Changes
1.2 (January 2020)	Updated system requirements for Mac and Windows support
1.1 (October 2019)	Clarified power requirements
1.0 (September 2019)	Updated information about performance settings
Beta (March 2019)	Initial release